



HIGH PERFORMANCE TRIACS

FEATURES

- $I_{TRMS} = 4\text{ A}$
- $V_{DRM} = 400\text{ V to }800\text{ V}$
- SENSITIVE GATE : $I_{GT} \leq 10\text{ mA}$
- HIGH COMMUTATION : $(di/dt)_c > 3.5\text{ A/ms}$

DESCRIPTION

The T410 / T435 high voltage TRIAC Families are high performance planar diffused PNPN devices glass passivated technology. Packaged either in TO220AB, SOT82, SOT194 and ISOWATT220AB these products are intended for all bi-directional switch applications.

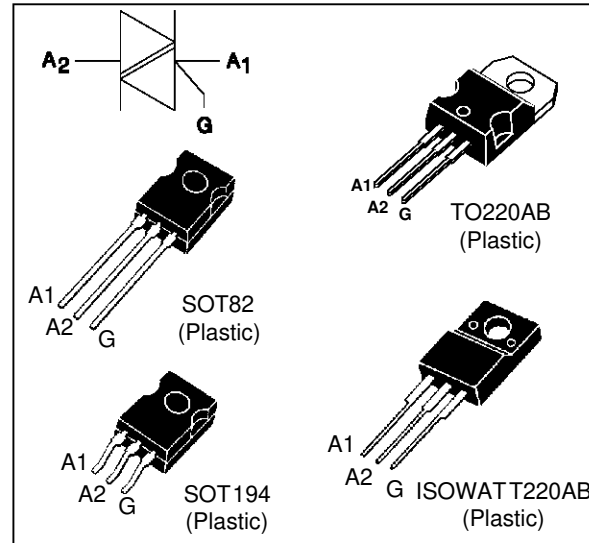

ABSOLUTE RATINGS (limiting values)

Symbol	Parameter		Value	Unit
$I_{T(RMS)}$	RMS on-state current (360° conduction angle)	TO220AB	4	A
		SOT194/SOT82		
		ISOWATT220AB	$T_c = 100\text{ °C}$	
I_{TSM}	Non repetitive surge peak on-state current (T_j initial = 25°C)	$t_p = 8.3\text{ ms}$	35	A
		$t_p = 10\text{ ms}$	30	
i^2t	i^2t value	$t_p = 10\text{ ms}$	4.5	A ² s
di/dt	Critical rate of rise of on-state current Gate supply : $I_G = 500\text{ mA}$ $di_G/dt = 1\text{ A}/\mu\text{s}$	Repetitive F = 50 Hz	10	A/ μs
		Non Repetitive	50	
T_{stg} T_j	Storage and operating junction temperature range		- 40 to + 150 - 40 to + 125	°C °C
TI	Maximum lead temperature for soldering during 10 s at 4.5 mm from case		260	°C

Symbol	Parameter	T410 or T435				Unit
		-400	-600	-700	-800	
V_{DRM} V_{RRM}	Repetitive peak off-state voltage $T_j = 125\text{ °C}$	400	600	700	800	V

THERMAL RESISTANCES

Symbol	Parameter		Value	Unit
Rth (j-a)	Junction to ambient	SOT82 / SOT194	100	°C/W
		TO220AB	60	
		ISOWATT 220AB	50	
Rth (j-c) DC	Junction to case for DC	SOT82 / SOT194 TO220AB	3.5	°C/W
		ISOWATT 220AB	5.3	
Rth (j-c) AC	Junction to case for 360° conduction angle (F= 50 Hz)	SOT82 / SOT194 TO220AB	2.6	°C/W
		ISOWATT 220AB	4	

GATE CHARACTERISTICS (maximum values)

$P_{G(AV)} = 1 \text{ W}$ $P_{GM} = 10 \text{ W}$ (tp = 20 μs) $I_{GM} = 4 \text{ A}$ (tp = 20 μs) $V_{GM} = 16 \text{ V}$ (tp = 20 μs).

ELECTRICAL CHARACTERISTICS

Symbol	Test Conditions		Quadrant		Suffix		Unit	
					T410	T435		
I_{GT}	$V_D=12\text{V}$ (DC) $R_L=33\Omega$	$T_j=25^\circ\text{C}$	I-II-III	MAX	10	35	mA	
V_{GT}	$V_D=12\text{V}$ (DC) $R_L=33\Omega$	$T_j=25^\circ\text{C}$	I-II-III	MAX	1.5		V	
V_{GD}	$V_D=V_{DRM}$ $R_L=3.3k\Omega$	$T_j=125^\circ\text{C}$	I-II-III	MIN	0.2		V	
tgt	$V_D=V_{DRM}$ $I_G = 500\text{mA}$ $di_G/dt = 3\text{A}/\mu\text{s}$ $I_{TM} = 5.5\text{A}$	$T_j=25^\circ\text{C}$	I-II-III	TYP	2		μs	
I_L	$I_G=1.2 I_{GT}$	$T_j=25^\circ\text{C}$	I-II-III	MAX	30	60	mA	
I_H *	$I_T= 100\text{mA}$ gate open	$T_j=25^\circ\text{C}$		MAX	15	35	mA	
V_{TM} *	$I_{TM}= 5.5\text{A}$ tp= 380μs	$T_j=25^\circ\text{C}$		MAX	1.75		V	
I_{DRM} I_{RRM}	V _{DRM} Rated V _{RRM} Rated	$T_j=25^\circ\text{C}$		MAX	0.01		mA	
		$T_j=125^\circ\text{C}$		MAX	2			
dV/dt *	Linear slope up to $V_D=67\%V_{DRM}$ gate open	$T_j=125^\circ\text{C}$		MIN	$V_{DRM} = 400\text{V} / 600\text{V}$	50	250	V/μs
					$V_{DRM} = 700\text{V} / 800\text{V}$	30	250	
(di/dt) _c *	$dV/dt = 0.1\text{V}/\mu\text{s}$	$T_j=125^\circ\text{C}$		MIN	2.7	4.4	A/ms	
	$dV/dt = 20\text{V}/\mu\text{s}$			MIN	1.8	2.7		

* For either polarity of electrode A2 voltage with reference to electrode A1.

ORDERING INFORMATION

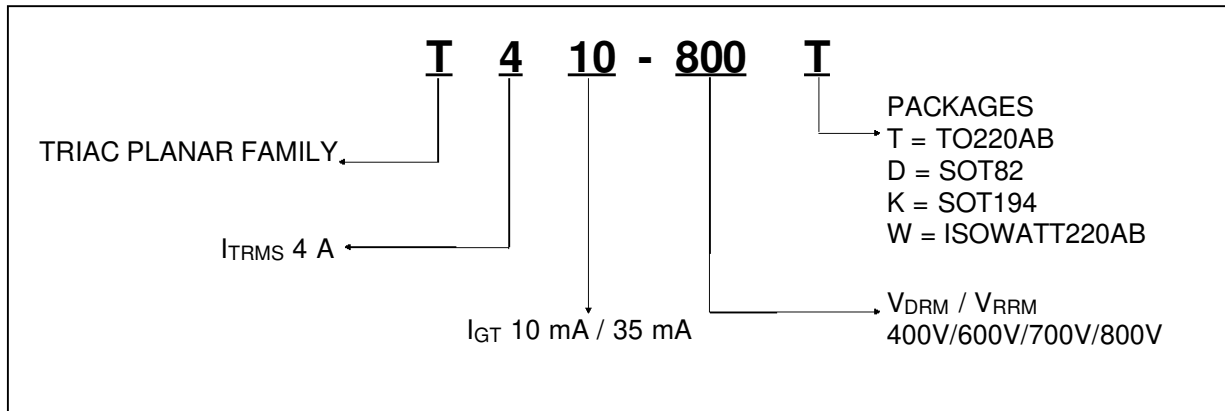

Fig.1 : Maximum RMS power dissipation versus RMS on-state current (F=50Hz).
(Curves are cut off by (di/dt)c limitation)

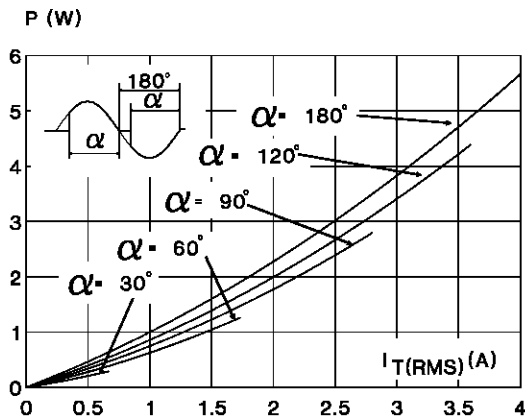

Fig.3 : Correlation between maximum RMS power dissipation and maximum allowable temperatures (Tamb and Tcase) for different thermal resistances heatsink + contact (ISOWATT220AB).

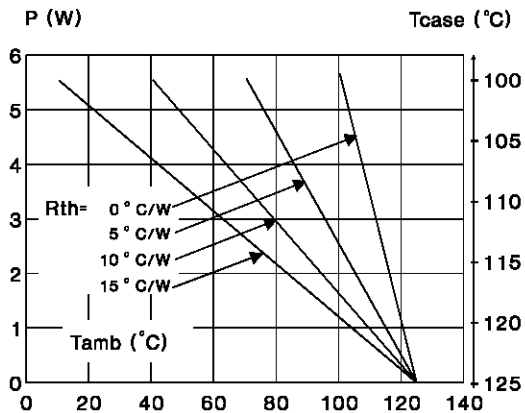

Fig.2 : Correlation between maximum RMS power dissipation and maximum allowable temperatures (Tamb and Tcase) for different thermal resistances heatsink + contact (TO220AB / SOT82 / SOT 94).

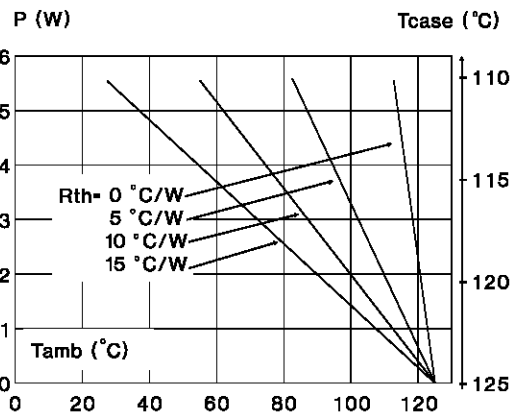

Fig.4 : RMS on-state current versus case temperature.

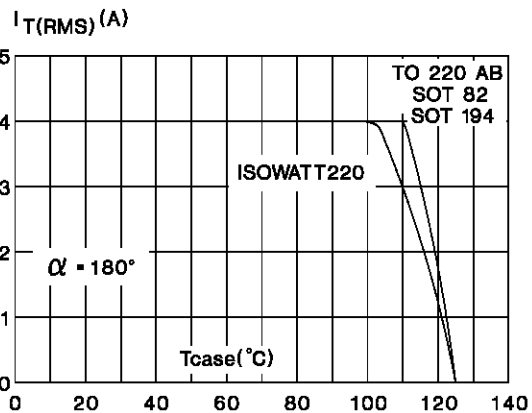

Fig.5 : Relative variation of thermal impedance versus pulse duration (SOT82 / SOT194 / TO220AB only).

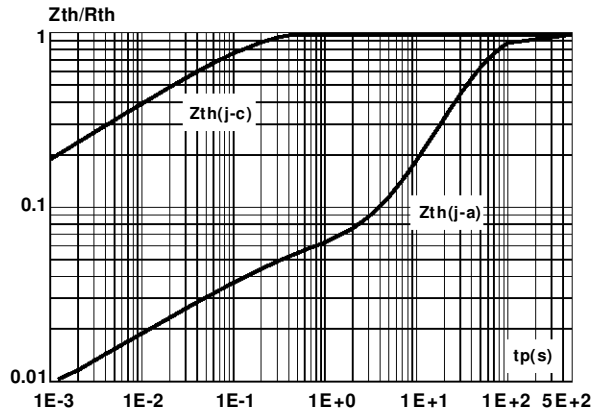

Fig.6 : Relative variation of thermal impedance versus pulse duration (ISOWAT T220AB only).

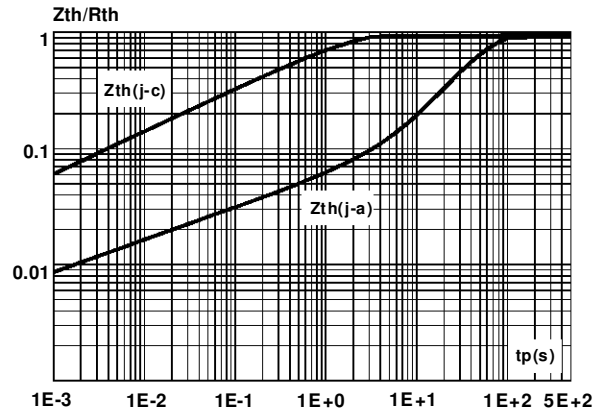

Fig.7 : Relative variation of gate trigger current and holding current versus junction temperature.

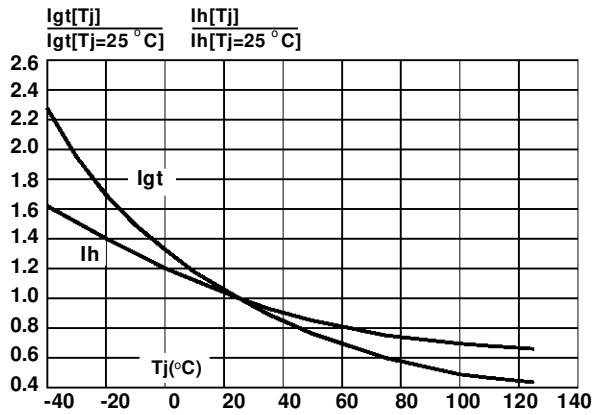

Fig.8 : Non Repetitive surge peak on-state current versus number of cycles.

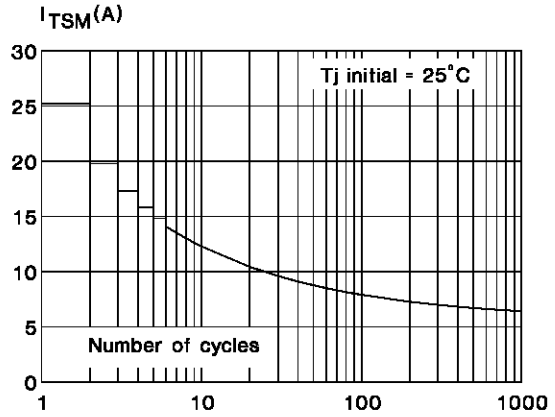

Fig.9 : Non repetitive surge peak on-state current for a sinusoidal pulse with width : $t \leq 10\text{ms}$, and corresponding value of I^2t .

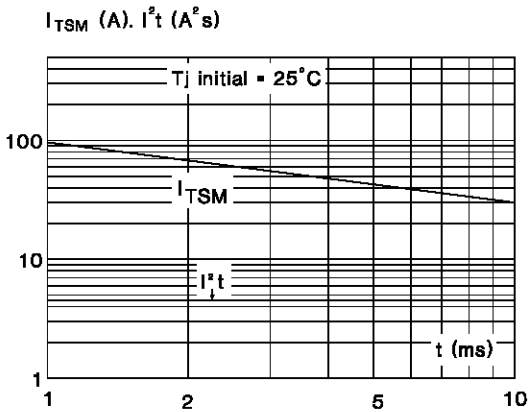
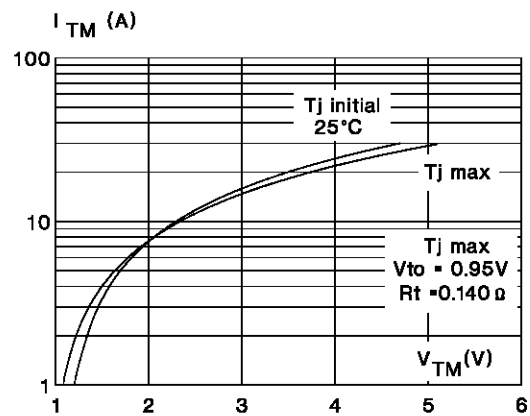
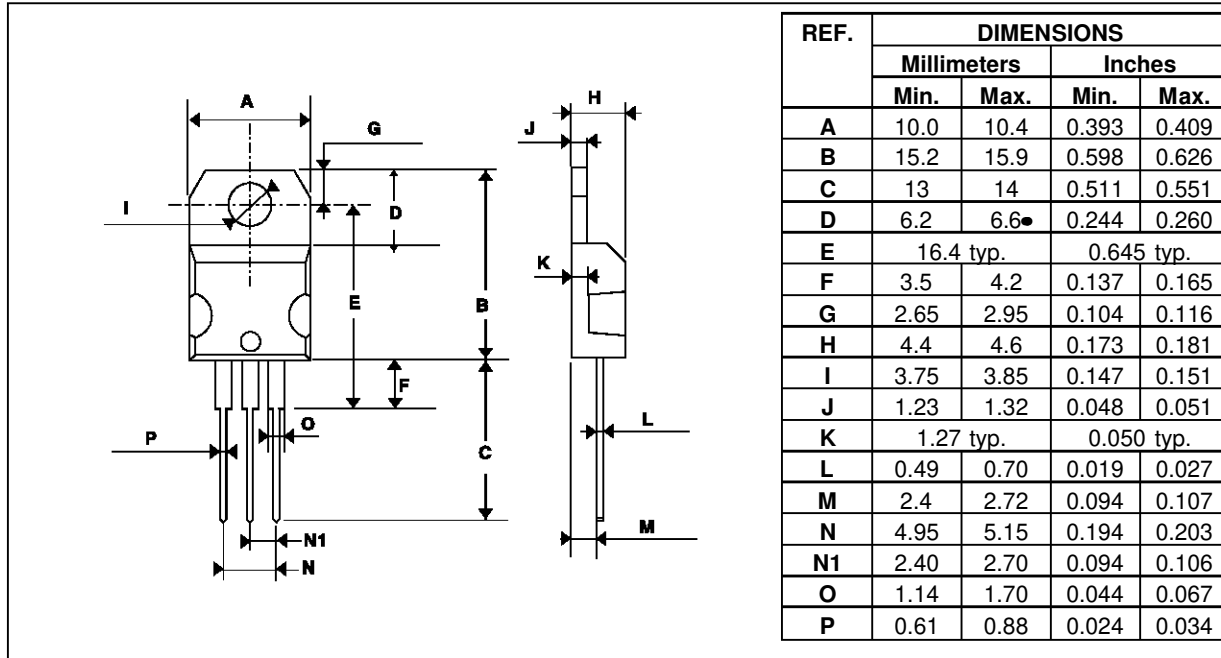

Fig.10 : On-state characteristics (maximum values).



PACKAGE MECHANICAL DATA
TO220AB Plastic



Cooling Method : C
 Marking : Type number
 Weight : 2 g
 Recommended torque value : 0.55 m.N.
 Maximum torque value : 0.70 m.N.

PACKAGE MECHANICAL DATA
ISOWATT220AB Plastic

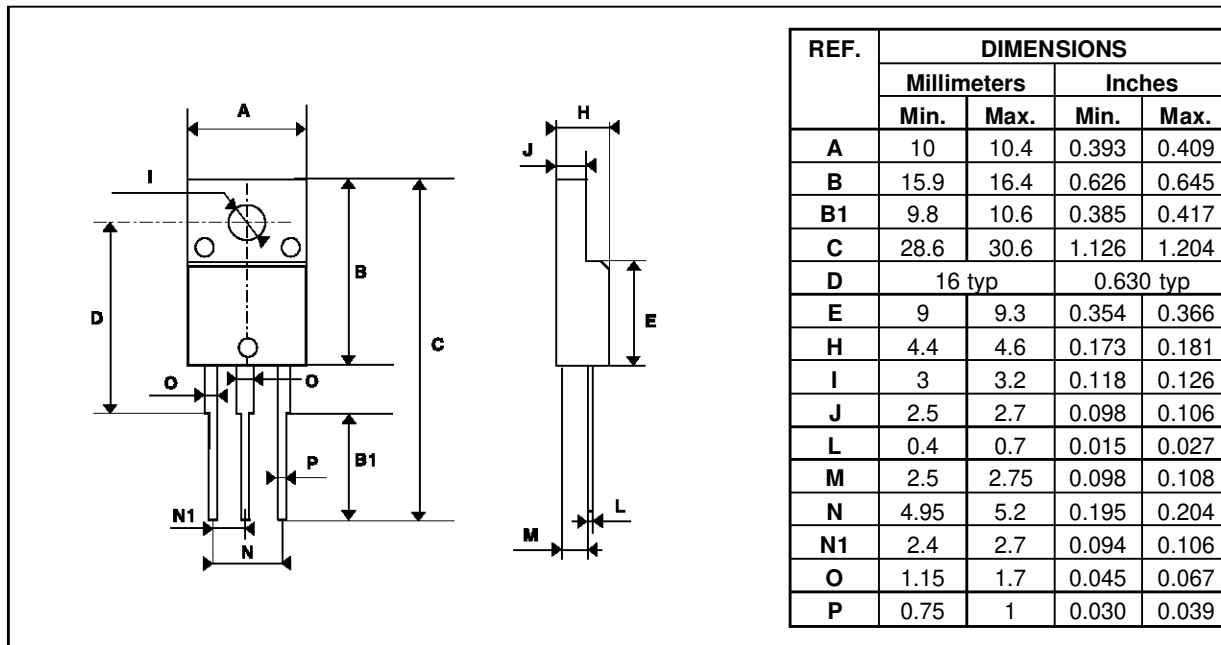

Cooling Method : C
 Marking : Type number
 Weight : 2.1g
 Recommended torque value : 0.55 m.N.
 Maximum torque value : 0.70 m.N.

T410 / T435

PACKAGE MECHANICAL DATA

SOT82 Plastic

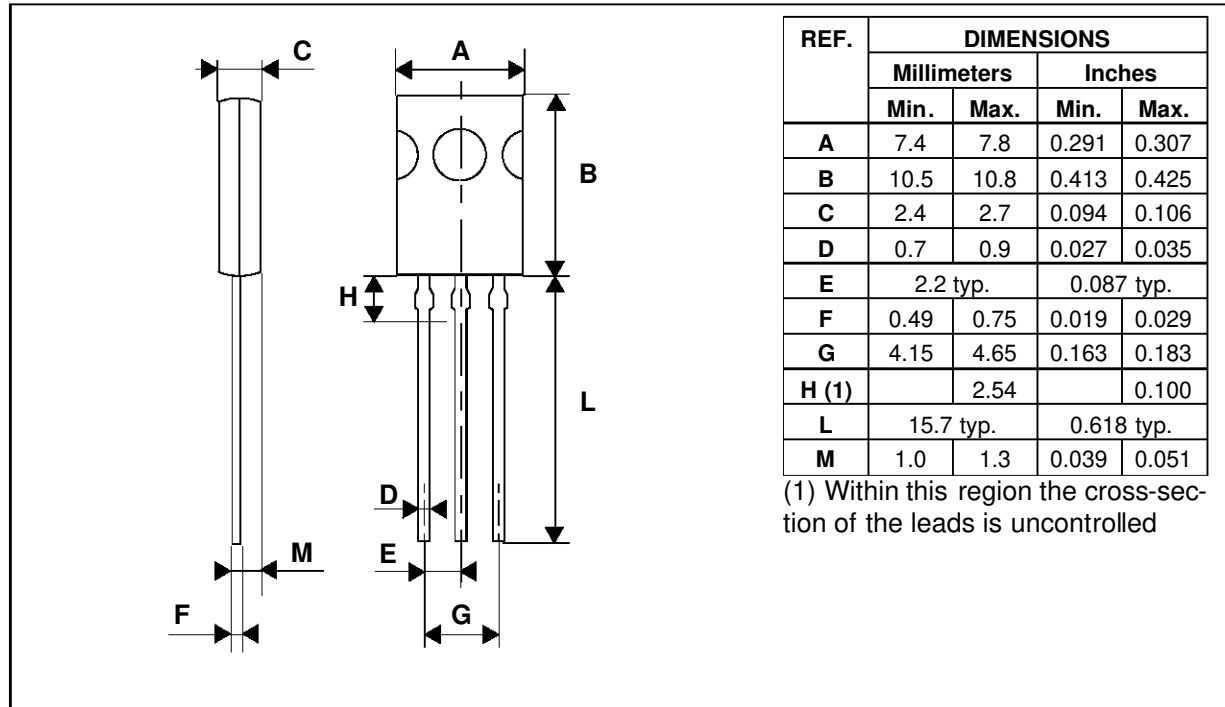

Marking : Type number
 Weight : 0.72g

PACKAGE MECHANICAL DATA

SOT194 Plastic

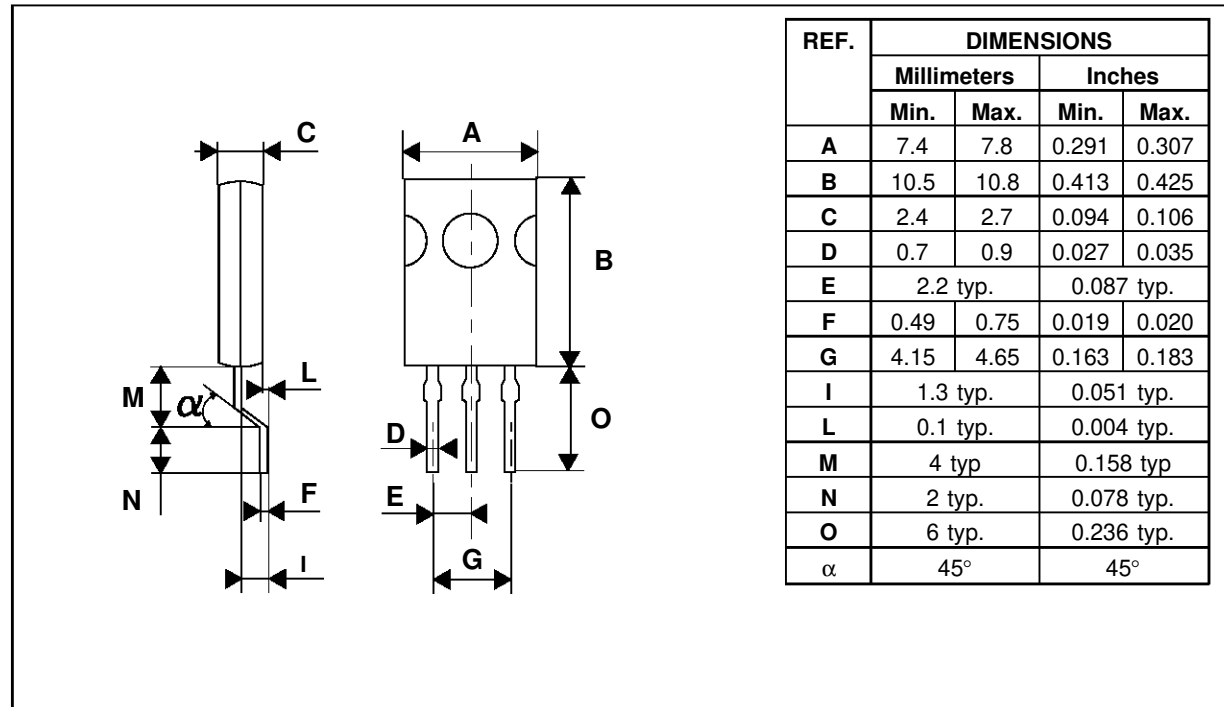

Marking : Type number

Weight : 0.68g

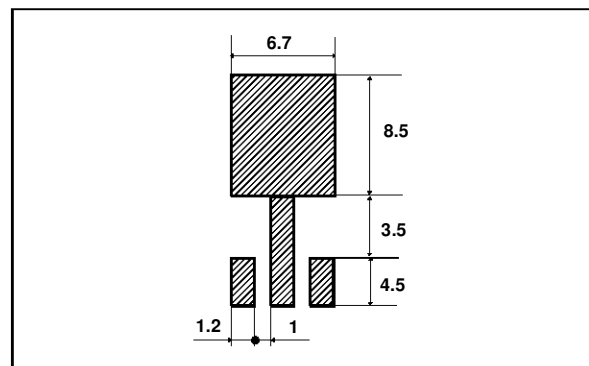
FOOT PRINT

Information furnished is believed to be accurate and reliable. However, SGS-THOMSON Microelectronics assumes no responsibility for the consequences of use of such information nor for any infringement of patents or other rights of third parties which may result from its use. No license is granted by implication or otherwise under any patent or patent rights of SGS-THOMSON Microelectronics. Specifications mentioned in this publication are subject to change without notice. This publication supersedes and replaces all information previously supplied.

SGS-THOMSON Microelectronics products are not authorized for use as critical components in life support devices or systems without express written approval of SGS-THOMSON Microelectronics.

© 1995 SGS-THOMSON Microelectronics - All rights reserved.

SGS-THOMSON Microelectronics GROUP OF COMPANIES

Australia - Brazil - France - Germany - Hong Kong - Italy - Japan - Korea - Malaysia - Malta - Morocco - The Netherlands - Singapore - Spain - Sweden - Switzerland - Taiwan - Thailand - United Kingdom - U.S.A.